

User's Manual

**Pressure transmitter
WX-PT700/PT900**

WellKonix Process Automation & Technologies Co.

Headquarters:
1.9883 St. John's Road
LEICESTER
LE8 2RB
England



Preface

Thank you for purchasing pressure transmitter. Please read this manual carefully before operating and using it correctly to avoid unnecessary losses caused by false operation.

Note

- Modification of this manual's contents will not be notified as a result of some factors, such as function upgrading.
- We try our best to guarantee that the manual content is accurate, if you find something wrong or incorrect, please contact us.
- This product is forbidden to use in explosion-proof occasions.

Version

U-WX-PT700/PT900-EN3-V6

Disclaimer

- The company does not make any guarantees for the terms outside the scope of this product warranty.
- This company is not responsible for damage to the instrument or loss of parts or unpredictable damage caused directly or indirectly by improper operation of the user.

No.	Name	Quantity	Note
1	Pressure transmitter	1	
2	Manual	1	
3	Certificate	1	

After opening the box, please confirm the package contents before starting the operation. If you find that the model and quantity are incorrect or there is physical damage in appearance, please contact us.

Contents

Chapter 1 Introduction.....	1
Chapter 2 Characteristics.....	2
Chapter 3 Dimension.....	3
Chapter 4 Parameter.....	8
Chapter 5 Wiring.....	10
5.1 DIN connector type.....	10
5.2 Cable connector type.....	12
Chapter 6 Function & Setting(PT900).....	13
6.1 Display.....	13
6.2 Definition.....	14
6.3 Monitoring menu.....	15
Chapter 7 Installation.....	22
Chapter 8 Safety instructions.....	24
Chapter 9 Cautions.....	25
Chapter 10 Warranty & After-sales Service.....	26

Chapter 1 Introduction

Imported high precision and high stability pressure sensitive chips are selected for diffused silicon pressure transmitter. Sensitive chips are fabricated by advanced micro-mechanical etching process, which forms Wheatstone bridge by diffusing four high-precision resistors with temperature compensation on silicon wafers. Because of piezoresistive effect, there are some changes on the resistance values of the four bridge arm resistance, so as to make the bridge unbalanced, and then the sensor outputs an electric signal corresponding to the change of pressure. The output electric signal is compensated by amplification and non-linear correction circuit, which generates voltage and current signals which correspond linearly to the input pressure.

Chapter 2 Characteristics

- (1) Compact structure and easy to install.
- (2) Advanced diaphragm/oil-filled isolation technology.
- (3) High stability and reliability.
- (4) Seismic resistance and anti-radio frequency interference.
- (5) 316L stainless steel isolation diaphragm structure.
- (6) High precision, all stainless steel structure.
- (7) Micro-amplifier, voltage and current signal output.
- (8) Strong anti-interference and long-term stability.
- (9) Variety of process connections are available.
- (10) Wide range of measurement. It can measure absolute pressure, gauge pressure and sealing reference pressure.
- (11) Anti-vibration and anti-impact.

Chapter 3 Dimension

□ P700

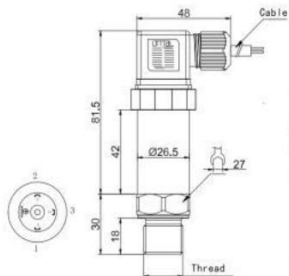

DIN connector type

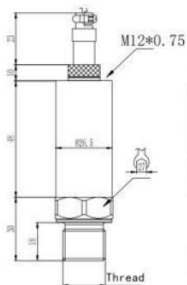

M12 connector type

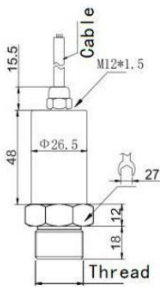

Cable connector type (Current voltage output)

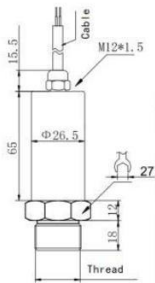

Cable connector type (RS485 output)

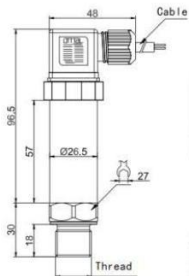

DIN connector type
(RS485 output)

□ PT710

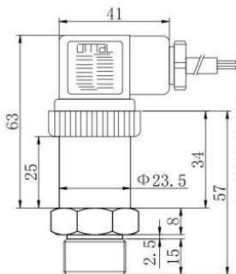

□ P700GX

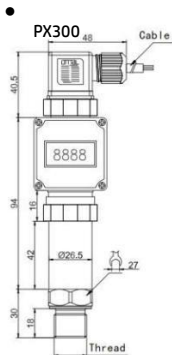
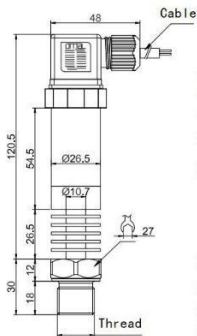

□ PT900 without display

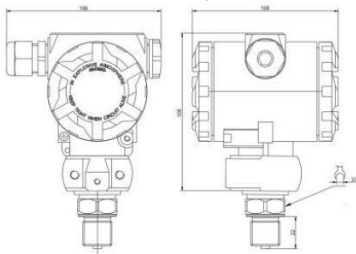

□ PT900 with display

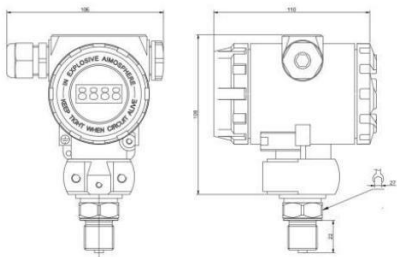

□ PT900GX

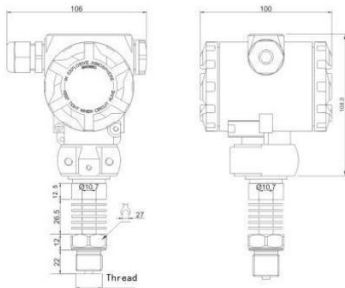

Chapter 4 Parameter

Power Supply	WX-PT700: (4~20)mA output:(10~32)V; (0~10)V output:(12~32)V; RS485 output:(8~32)V;
	PT900 with display: (4~20) mA output:(12~32)V; (4~20) mA+RS485 output:(10~32)V
	PT900 without display: (4~20) mA output:(9~32)V
Output	(4~20)mA;(1~5)V; (0~10)V;(0~5)V;RS485
Accuracy	0.2%、0.25%、0.5%
Measurement range	-0.1...0...60Mpa
Pressure type	gauge pressure, adiabatic pressure and sealed pressure
Compensation temperature	-10°C~70°C
Working temperature	-20°C~85°C
Medium temperature	-20°C~85°C
Storage temperature	-40°C~85°C
Zero-point temperature drift	±0.3%FS/10°C

Sensitivity temperature drift	$\pm 0.3\%FS/10^{\circ}C$
Overload pressure	(0.035~10)MPa (150%FS) (10~60)MPa (125%FS)
Long-term stability	$\pm 0.2\%FS/year$
Response time	RS485 output $\leq 100ms$ (up to 90% FS) Current and Voltage output $\leq 10ms$ (up to 90% FS)
Insulation	20M Ω /250VDC
Ingress protection	IP65
Load Resistance	(U-9V)/0.02A

Chapter 5 Wiring

5.1 DIN connector type

Wiring of DIN connector type as follows:

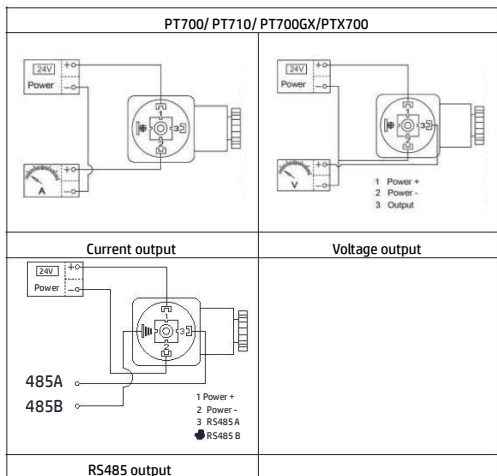

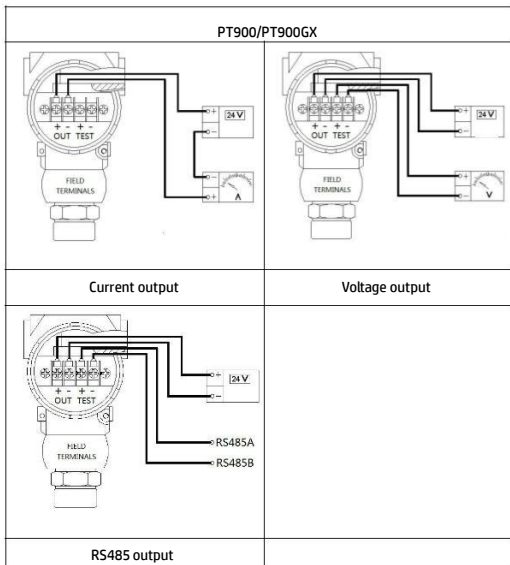

5.2 Cable connector type

Wiring of cable connector type as follows:

Current:	Red Wire: 24V +
	Green Wire: Current Output
Voltage:	Red Wire: 24V +
	Green Wire: 24V -
	Yellow Wire: Voltage Output
RS485 :	Red Wire : 24V +
	White Wire : 24V -
	Green Wire : RS485+
	Yellow Wire : RS485-

Chapter 6 Function & Setting (PT900)

6.1 Display

The main display area and the sub-display area of the screen have a variety of display functions. There are three kinds of display on the main screen, namely pressure value display, percentage display and current display. The sub-display has two different options: temperature display and no display. The temperature value comes from the temperature sensor on the circuit board, and the display switch can be carried out at any time. The way each click is displayed depends on the mode value that the software saved at the end. The display mode set on the panel will be cleared after the next power failure.



6.2 Definition



"M"

- (1) Press "on" to enter the password setting in the measurement mode.
- (2) Press and hold for 5 seconds in the measurement mode to enter the principal variable reset (i.e., PV reset).
- (3) In the setting mode, press the keys for a second to enable parameter modification, and the modified parameter flashes. Press the keys again to confirm parameter modification, and the modified parameter stops flickering.

"S"

- (1) Press shortly in the measurement mode to modify the display mode.
- (2) Press and hold in the measurement mode for 5

seconds to enter the filling function (the calibration transmitter is full, which will involve the accuracy and performance. Do not operate in the case of no standard source).

(3) In setting mode, add one function for setting parameters, and long time continuous shift plus one.

"Z"

(1) Press shortly in the measurement mode to modify the display mode.

(2) Press and hold for 5 seconds in the measurement mode to enter the zero function (to calibrate the transmitter zero point).

(3) In the setting mode, for setting parameter displacement and reduce function, to shift or subtract one continuously in a long time.

6.3 Monitoring menu

There are two types of access codes, depending on the size of the transmitter.

(1) 4~20mA output: the entry password is "00001", and the display unit, display resolution and display mode can be set.

(2) RS485/RS485&4~20mA output: the entry password is "00016", which can be set as shown in table 1.

Function setting (4~20mA output)

Loc: password input menu, range can be set (19999 ~ 99999),

menu prompt "PIN".

Set the password to enter the menu. If you enter the password incorrectly or there is no keys operation within 30 seconds, you will automatically return to the measurement mode.

Unt: user unit Settings, settable range (0 to 18), menu prompt for setting each unit.

19 types of unit settings, respectively "MPa", "KPa", "Pa", "bar", "mbar", "PSI", "mH₂O", "mmH₂O", "InH₂O", "ftH₂O", "mHg", "mmHg", "InHg", "Kg/cm²", "ATM", "Torr", "m", "cm", "mm".

Dot: display precision setting, settable range(0 ~ 4), menu prompt is the current pressure unit

The display resolution is the decimal digits of decimal places displayed in the measurement mode. Users can set it according to the requirements of field use. It is not better to display more decimal places, and the stability of the display value should be given priority. At the same time, this menu value will be limited by the maximum transmitter display value during calibration. If the set number of decimal points is out of the 5-bit display range when the maximum display value of the transmitter is displayed, the set number of decimal points will be limited to the range where the maximum display value can be displayed normally.

For example: the calibration range of transmitter is 0.0000 ~ 20.000MPa; then the setting range of display precision is (0

~ 3). If the setting value of display precision is 4, the maximum display value will exceed the maximum display range of 5 bits.

SH0: display mode setting, range can be set (0 ~ 5)

"0" -- shows the main variable at the prompt "-pv -"

"1" -- shows current, prompt "-ma -"

"2" -- shows percentages, prompt "-%-"

"3" -- the main variable is displayed alternately with the current, and the prompt is "pv-ma".

"4" -- the main variable is displayed alternately with the percentage, and the prompt is "PV--%".

"5" -- current and percentage are shown alternately, prompt "mA--%"

End: exit the setting menu, and the range can be set (0 ~ 1).

"0" - do not save the set value, and exit the set state, prompt "NSAVE"

"1" - SAVE the set value and exit the set state, prompt "SAVE"

Function setting (RS485 output /RS485 output & 4~20mA output)

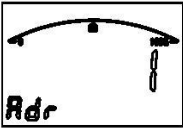
ADR		RS485, range 1-25
-----	--	-------------------

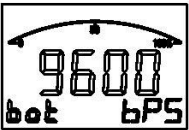
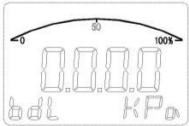
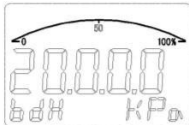
BOT	 <p>The LCD display shows a curved arrow at the top with a central dot. Below the arrow, the number '9600' is displayed in large digits. Underneath the number, the text 'bot' is on the left and 'bPS' is on the right.</p>	<p>Communication baud rate setting, baud rate range: 1200,2400,4800,9600,19200,38400,57600,115200bps Interface display: 1200, 2400, 4800, 9600, 19200, 38400, 57600, 11520.</p>
BDL	 <p>The LCD display shows a curved arrow at the top with '0' on the left, '50' in the center, and '100%' on the right. Below the arrow, the number '0000' is displayed in large digits. Underneath the number, the text 'bdL' is on the left and 'kPa' is on the right.</p>	<p>The value of the pivot variable corresponding to 4mA is transferred, it will be used as the zero of the transform when the range is scaled, which determines the pressure point of 20mA output in the transmitter.</p>
BDH	 <p>The LCD display shows a curved arrow at the top with '0' on the left, '50' in the center, and '100%' on the right. Below the arrow, the number '20000' is displayed in large digits. Underneath the number, the text 'bdH' is on the left and 'kPa' is on the right.</p>	<p>The value of the pivot variable corresponding to 20mA is transferred, it will be used as the zero of the transform when the range is scaled, which determines the pressure point of 20mA output in the transmitter.</p>

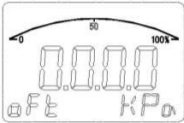
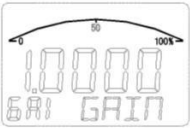
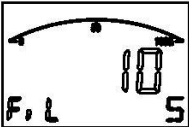
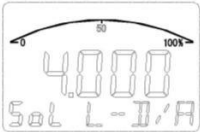
OFT		<p>The zero offset value of the transmitter's main variable, which is superimposed on the main variable. Zero point transformation of transmitter can be realized.</p>
GAI		<p>The gain coefficient of the main variable does not perform gain corrections to offset and reset values. The resolution is 0.0001FS, which aims to perform secondary calibration for the customer.</p>
FIL		<p>The value of filtering and damping are set to a maximum of 30 and a minimum of 0. The larger the value, the stronger the filtering effect.</p>
SOL		<p>The modification of board card 4mA calibration is to observe the current of the external ammeter, and the modification of the data and adjustment of the ampere meter current can receive an accurate 4mA.</p>

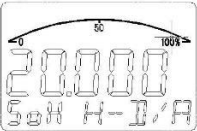
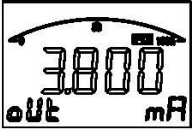
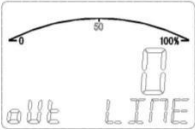
SOH		<p>The modification of board card 20mA calibration is to observe the current of the external ammeter, and the modification of the data and adjustment of the ampere meter current can receive an accurate 20mA.</p>
OUT FIX		<p>Current test menu and sub-menu into the modification mode can make the transmitter output menu display current value, in order of 3.800, 4.000, 8.000, 12.000, 16.000, 20.000, 20.800, 22.500mA current.</p>
OUT		<p>This menu sets the output of the transmitter to be either linear or square root. The square root output is generally suitable for the flow calculation of differential pressure transmitters. For general, select linear output.</p>

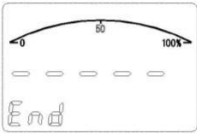
END		<p>This menu sets the output of the transmitter to be either linear or square root. The square root output is generally suitable for the flow calculation of differential pressure transmitters. For general, select linear output.</p>
-----	---	---

Chapter 7 Installation

- (1) Pressure transmitter should be installed as far as possible in the place where temperature fluctuation is small, while avoiding vibration and shock.
- (2) The pressure transmitter can be directly installed at the measuring point. Connection threads: M20*1.5 or 1/2-NPT. Flange Interfaces of various specifications for special purposes.
- (3) Transmitter is suitable for measuring the pressure of various general corrosive liquids and gas. Transmitters manufactured according to explosion-proof requirements can be used in different explosive environments according to the explosion-proof grade of products, and their related equipment should also have explosion-proof function. For strong corrosive medium (such as acid, alkali) and corrosion resistant structure, the orders should be placed according to special requirements.
- (4) Do not route the signal line through the conduit or the open cable with the power line, or near high-power equipment.
- (5) If the pressure pipes are used in the transmitter, attention should be paid to that the strong corrosive or superheated media should not contact the transmitter, so as to prevent the sediment from precipitating in the

pressure pipes, and the pressure pipes should be as short as possible. When measuring steam or other high temperature medium, the working temperature of the transmitter should not exceed the limit. When used for steam measurement, the pressure pipes should be filled with water to prevent the transmitter from contacting directly with the steam.

Chapter 8 Safety instructions

- (1) The cap must be tightened by hand, and the connection hole must be sealed with suitable seals to prevent water accumulation in the shell.
- (2) The transmitter shall not be loosened at the sealing joint and must be kept reliable.
- (3) Transmitters must be used according to specifications, and different types cannot be interchanged.
- (4) Transmitter range can be reduced, but the upper limit of range must not be exceeded 1.5 times of the range.

Chapter 9 Cautions

- (1) The transmitter is used in a medium without corrosion to silicon and stainless steel (or aluminum alloy).
- (2) The maximum pressure of the measured system may not exceed the rated value of 150% FS at the moment of instantaneous occurrence.
- (3) The back end of the pressure transmitter should not be in contact with conductive, corrosive liquids or gases.
- (4) It is not possible to insert a sharp object into the pressure input hole in order to prevent damage to the core.
- (5) The water can not enter the back-end lead of the sensor.
- (6) When using, please strictly follow the precautions, otherwise the consequences are at your own risk.

Chapter 10 : Warranty & After-sales Service

We promise to the customer that the hardware accessories provided during the supply of the instrument have no defects in material and manufacturing process.

From the date of the purchase, if the user's notice of such defects is received during the warranty period, the company will unconditionally maintain or replace the defective products without charge, and all non-customized products are guaranteed to be returned and replaced within 7 days.

Disclaimers:

□ During the warranty period, product faults caused by the following reasons are not in the scope of Three Guarantees service

□ Product faults caused by improper use by customers.

□ Product faults caused by disassembling, repairing and refitting the product.

After-sales service commitment:

□ We promise to deal with the customer's technical questions within 2 hours.

□ For the instruments returned to the factory for maintenance, we promise to issue the test results within 3 working days and the maintenance results within 7 working days after receiving them.